



Our Focus is in Plastics

Polymer Optics Ltd.

6 Kiln Ride, Wokingham,
Berks., RG40 3JL, England
Tel/Fax: +44 (0) 1189 893341
www.polymer-optics.co.uk

6 Degree LED Collimator 7 Cell Cluster Optic - Part No. 122

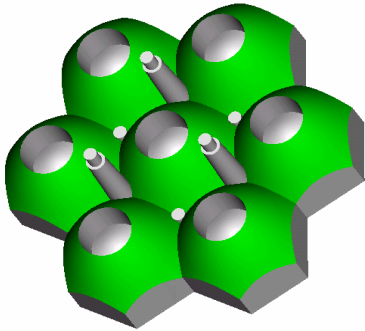

- Designed for Seoul Semiconductor Z Power P3 and P4 Emitters
- High light collection efficiency of >85%
- Precision moulded in optical grade Polycarbonate for thermal stability and system durability
- Part of the Polymer Optics “Modular LED Optics”® range

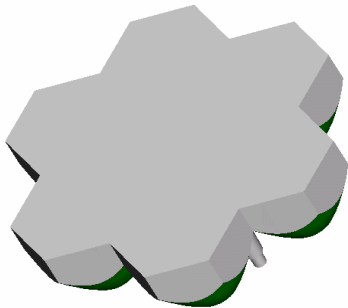

Typical dimensional tolerances
to +/-0.2mm

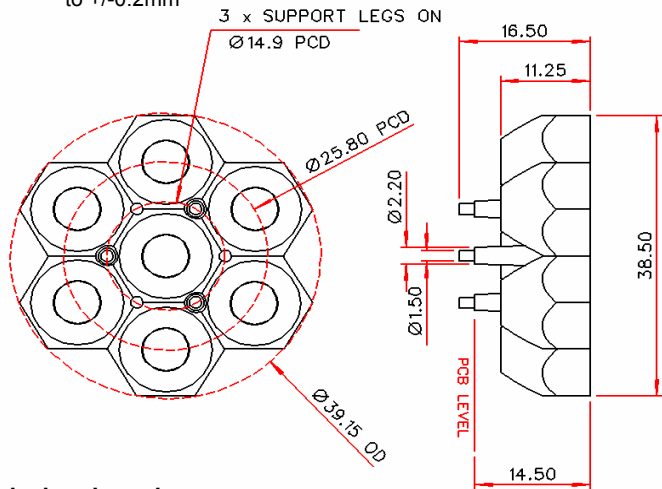

Polymer Optics “Modular LED Optics”® design, based on a hexagonal format, allows maximum packing density and assembly flexibility

Polymer Optics “Cluster Optic”® arrays can be assembled together in a number of ways to meet the needs of a range of illumination applications

The 122 and 125 type “Cluster Optics”® can be mixed in the assembly to optimise the systems illumination distribution, and combined with other Polymer Optics custom cluster designs.

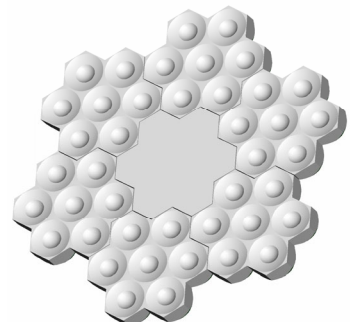

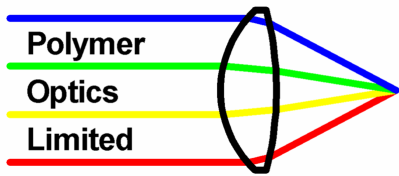

Our Focus is in Plastics

Polymer Optics Ltd.

6 Kiln Ride, Wokingham,
Berks., RG40 3JL, England
Tel/Fax: +44 (0) 1189 893341
www.polymer-optics.co.uk

6 Degree LED Collimator 7 Cell Cluster Optic - Part No. 122

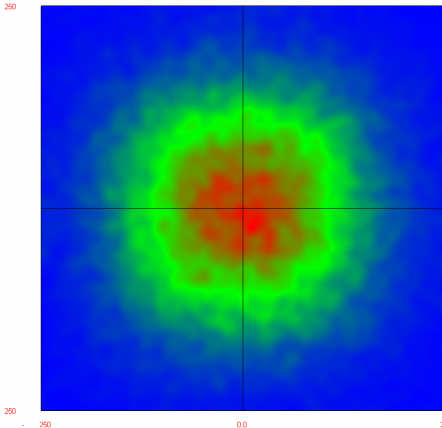

Raytrace Simulation of Typical Beam at 1m with 7 x 1W White LED's

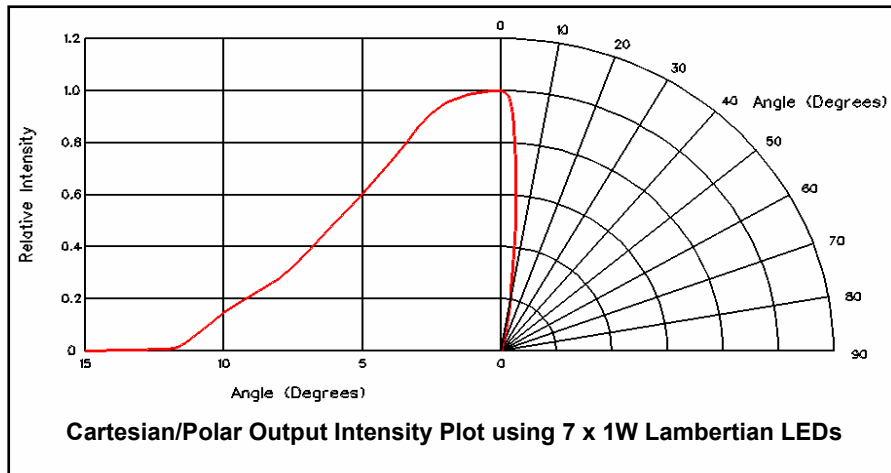
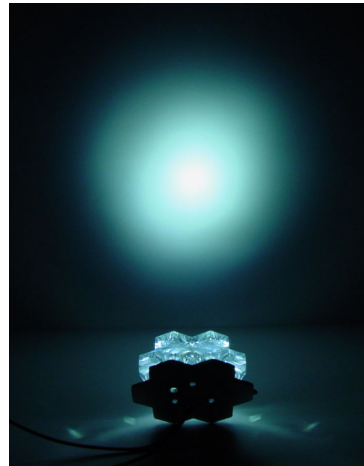

Typical illuminance values using 7 x 1W 25 lumen white LED = 15.5 cd/lumen			
Range	0.5m	1m	2m
Illuminance	10,800 lux	2700 lux	675 lux

Performance values given are typical values and will vary dependant on LED binning, colour and drive profile

Output beam is rendered homogeneous within only 100mm from front of optic. This gives excellent colour mixing with RGB LED mixes