

Our Focus is in Plastics

Polymer Optics Ltd.

6 Kiln Ride, Wokingham,
Berks., RG40 3JL, England
Tel/Fax: +44 (0) 1189 893341
www.polymer-optics.co.uk

7 Cell Cluster Concentrator Optic - Part No. 140

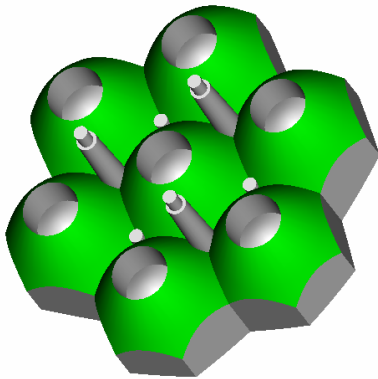

- Designed for Edison Edixeon Emitter and Star LED's
- High light collection efficiency of >85%
- Precision moulded in optical grade Polycarbonate for thermal stability and system durability
- Part of the Polymer Optics "Modular LED Optics"® range

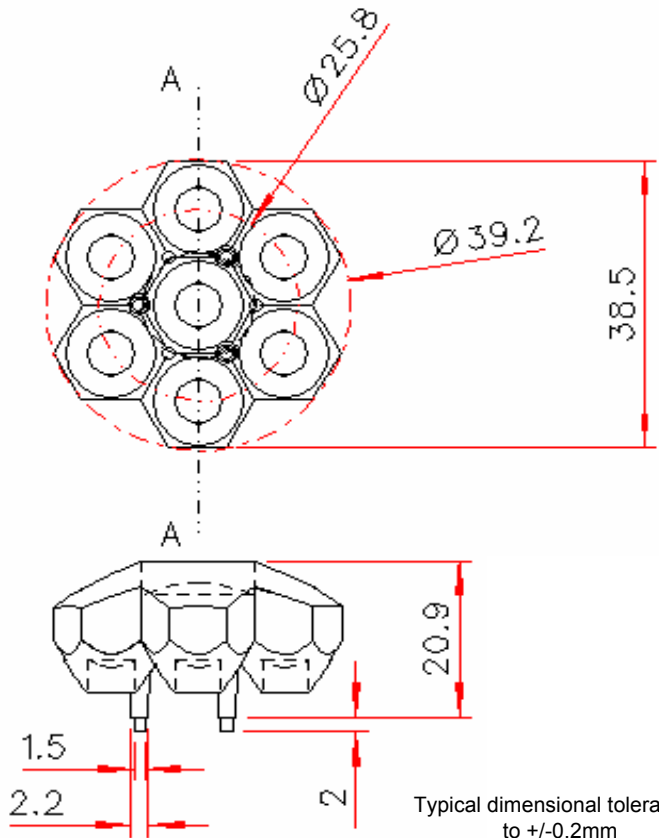
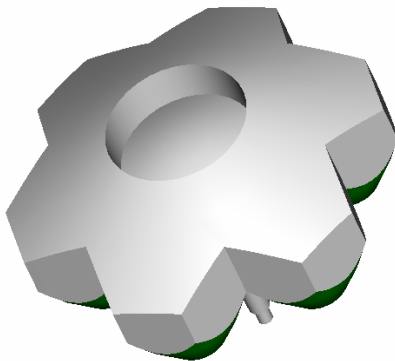

Typical dimensional tolerances to $\pm 0.2\text{mm}$

Polymer Optics "Modular LED Optics"® design, based on a hexagonal format, allows maximum packing density and assembly flexibility

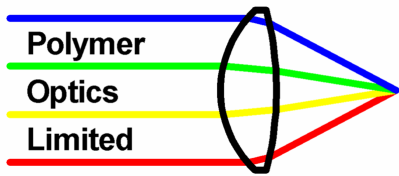

Our Focus is in Plastics

Polymer Optics Ltd.

6 Kiln Ride, Wokingham,
Berks., RG40 3JL, England
Tel/Fax: +44 (0) 1189 893341
www.polymer-optics.co.uk

7 Cell Cluster Concentrator Optic - Part No. 140

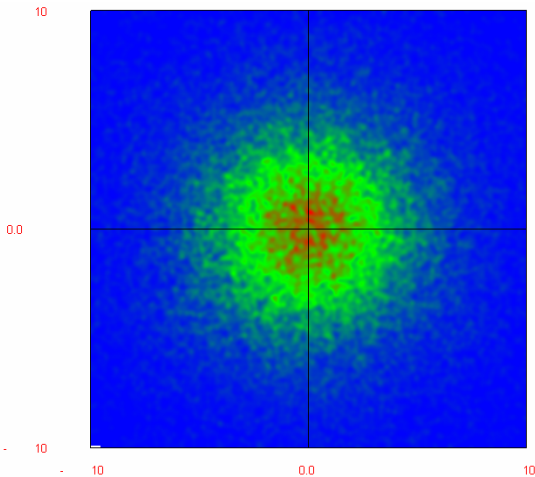
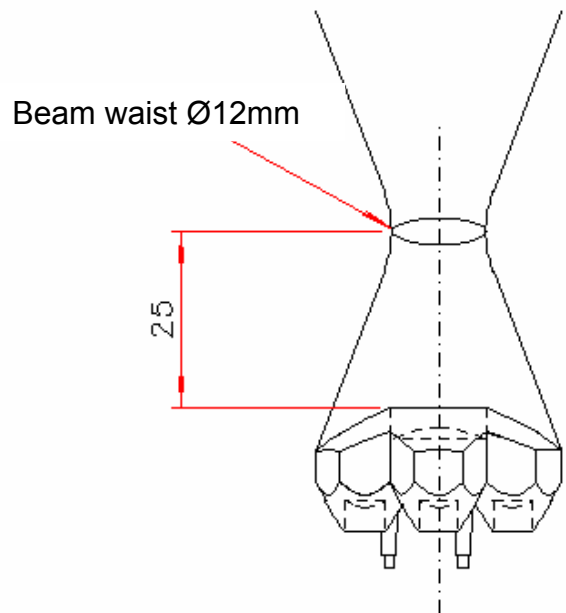

Raytrace Simulation of Typical Beam at 25mm on a 20mm x 20mm target with 7x1W 25lumen White LED's

Typical Applications:

- Beam insertion into optical fibre bundles
- Beam insertion into edge of lightguides
- High intensity illumination of small objects for inspection and microscopy

Typical focused beam intensity at the 12mm aperture is **>3,000,000 lux**

Performance values given are typical values and will vary dependant on LED binning, colour and drive profile