



Our Focus is in Plastics

Polymer Optics Ltd.

6 Kiln Ride, Wokingham,
Berks., RG40 3JL, England
Tel/Fax: +44 (0) 1189 893341
www.polymer-optics.co.uk

7 Cell Cluster Concentrator Optic - Part No. 140

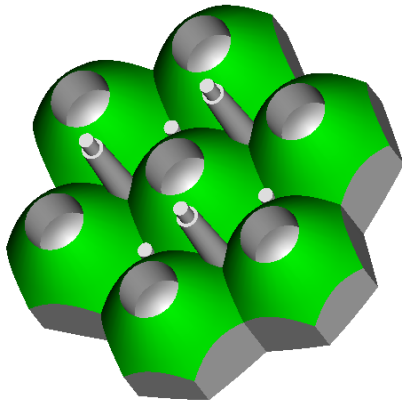

- Designed for LUXEON® I, III and K2 LED's
- High light collection efficiency of >85%
- Suitable for LUXEON® “Lambertian” and “Bat-wing” LED designs.
- Precision moulded in optical grade Polycarbonate for thermal stability and system durability
- Part of the Polymer Optics “Modular LED Optics”® range

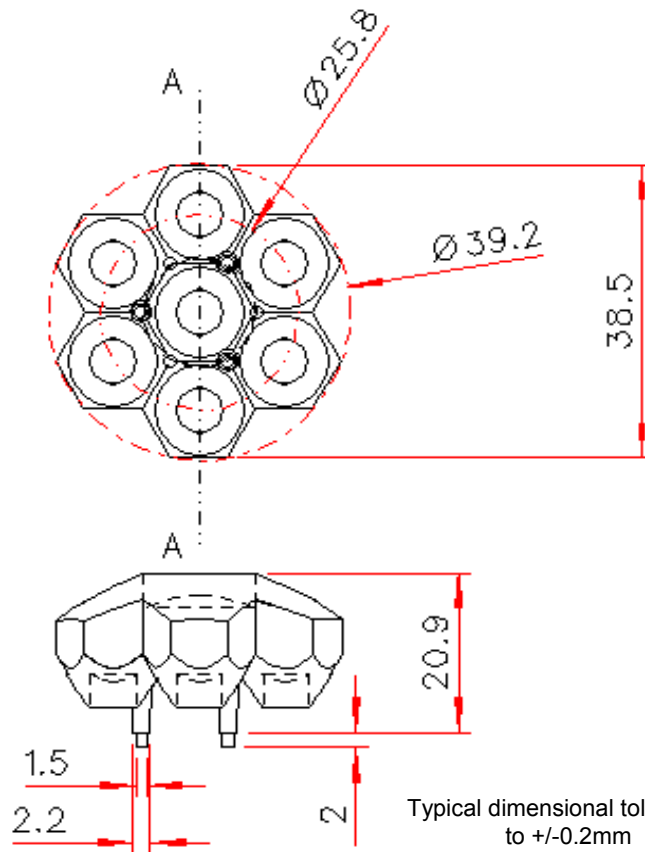
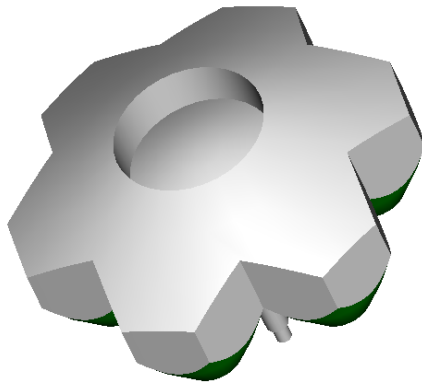

Typical dimensional tolerances to +/-0.2mm

Polymer Optics “Modular LED Optics”® design, based on a hexagonal format, allows maximum packing density and assembly flexibility



Polymer
Optics
Limited

Our Focus is in Plastics

Polymer Optics Ltd.

6 Kiln Ride, Wokingham,
Berks., RG40 3JL, England
Tel/Fax: +44 (0) 1189 893341
www.polymer-optics.co.uk

7 Cell Cluster Concentrator Optic - Part No. 140

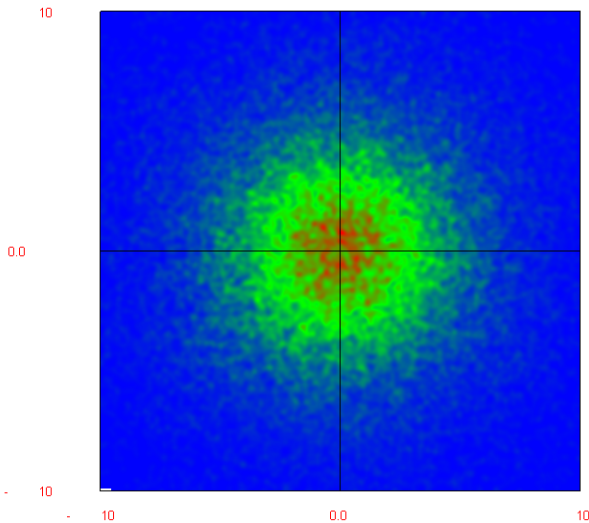
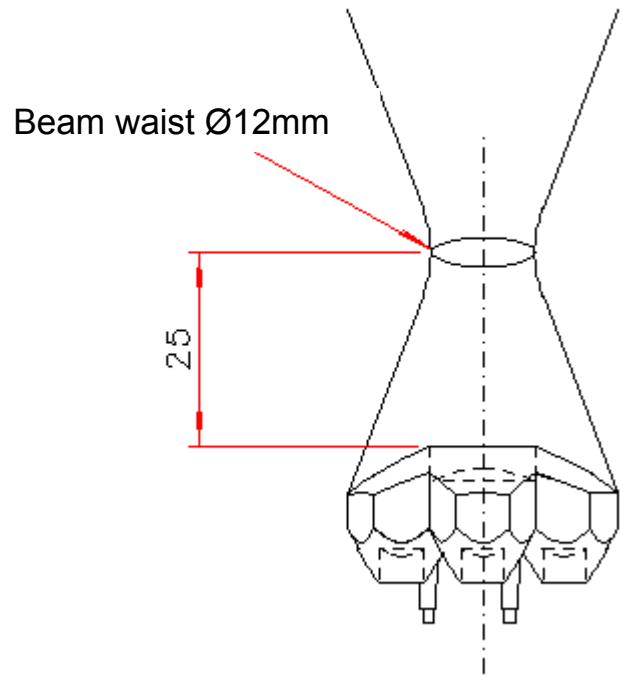

Typical Applications:

- Beam insertion into optical fibre bundles
- Beam insertion into edge of lightguides
- High intensity illumination of small objects for inspection and microscopy

Typical focused beam intensity at the 12mm aperture is >3,000,000 lux

Raytrace Simulation of Typical Beam at 25mm on a 20mm x 20mm target with 7x1W 25lumen White LED's

Performance values given are typical values and will vary dependant on LED binning, colour and drive profile