



**Polymer
Optics
Limited**

Our Focus is in Plastics

Polymer Optics Ltd.

6 Kiln Ride, Wokingham,
Berks., RG40 3JL, England
Tel/Fax: +44 (0) 1189 893341
www.polymer-optics.co.uk

30mm +/-2.5 Deg (5 Deg) Reflector Collimator for Rebel LED- Part No. 202



- Designed for LUXEON® Rebel LEDs
- High light collection efficiency of >85%
- Precision moulded using POL's patent applied for metallised optical insert moulding technique with a polycarbonate frame construction for superior mechanical and thermal stability
- Also available for other LUXEON® LED package types
- Part of the Polymer Optics "Modular LED Optics"® range

Polymer Optics "Modular LED Optics"® design, based on a hexagonal format, allows maximum packing density and assembly flexibility. Arrays of single colour or colour mixed cells can be easily constructed

The 202 Reflector Optic base is designed to locate into the PCB to align to the LUXEON® Rebel LED package and the enclosed base allows the PCB surface to be potted, if required

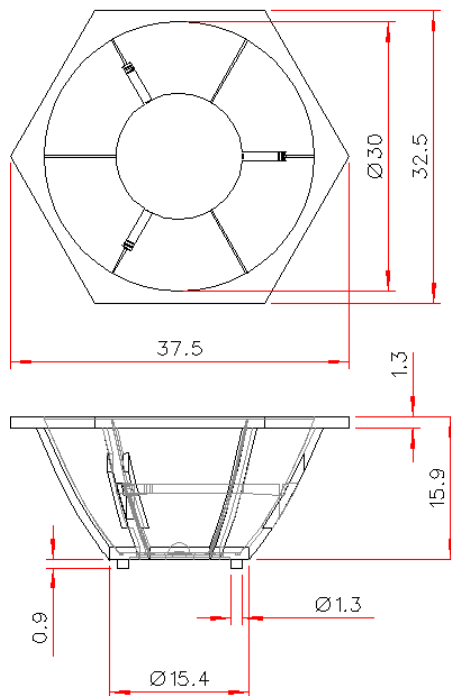
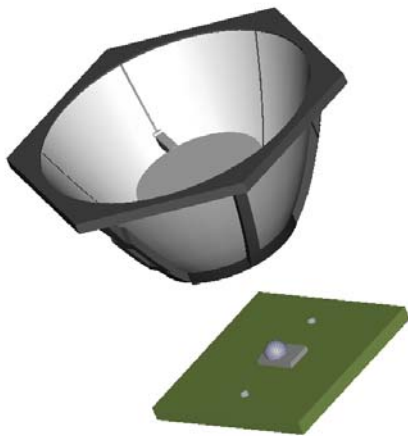

SCRAP VIEW SHOWING PCB LOCATION PINS

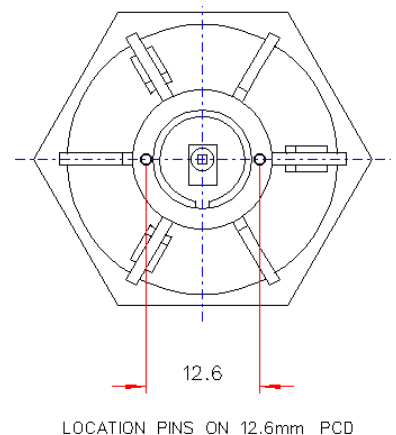

Typical dimensional tolerances to +/-0.2mm



Our Focus is in Plastics

Polymer Optics Ltd.

6 Kiln Ride, Wokingham,
Berks., RG40 3JL, England
Tel/Fax: +44 (0) 1189 893341
www.polymer-optics.co.uk

30mm +/-2.5 Deg (5 Deg) Reflector Collimator for Rebel LED- Part No. 202



The POL 202 optic's narrow, high intensity beam is ideal for demanding applications, such as:

- ✓ Mining and caving lamps
- ✓ Under water lamps and torches
- ✓ Architectural spot lights (single colour and RGB arrays)
- ✓ Theatrical lights and follow-spots (single colour and RGB arrays)
- ✓ High performance torches
- ✓ High level flood lights
- ✓ Street lights
- ✓ Medical lighting applications

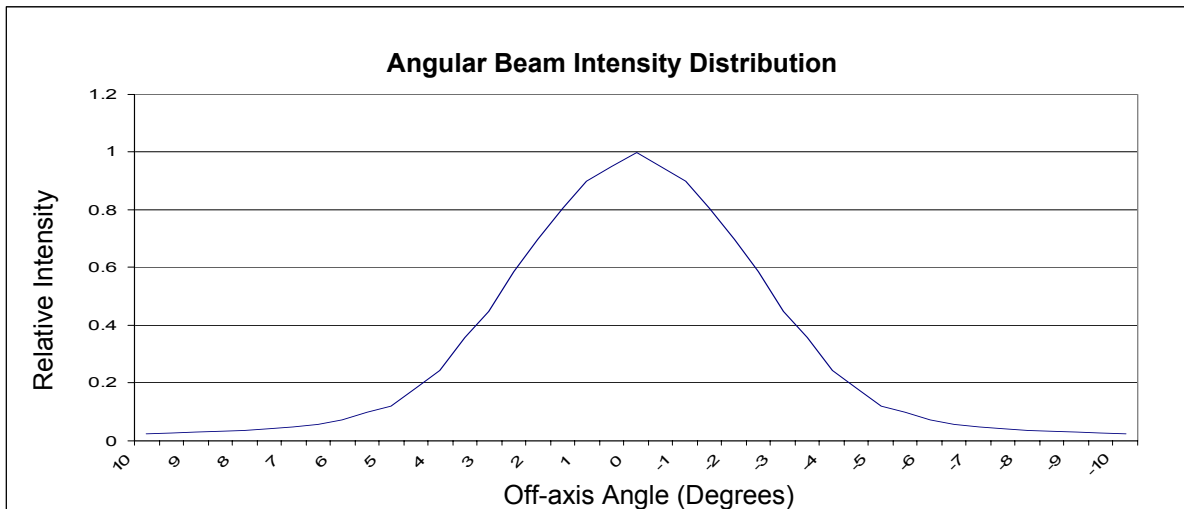

Typical illuminance values using 100 lumen Luxeon Rebel LED = 41.8 cd/lumen			
Range	0.5m	1m	2m
Illuminance	16720 lux	4180 lux	1045 lux

Performance values given are typical values and will vary dependant on LED binning, colour and drive profile