



Our Focus is in Plastics

Polymer Optics Ltd.

6 Kiln Ride, Wokingham,
Berks., RG40 3JL, England
Tel/Fax: +44 (0) 1189 893341
www.polymer-optics.co.uk

14mm Linear 15° LED Collimator Optic for Stanley 6US LEDs - Part No. 210



- Designed for Stanley 6US type LED's
- High light collection efficiency of >85%
- Linear design allows complete design flexibility of LED number, groupings and spacings
- Subtle diffuse surface finish applied to the Linear Optic provides improved tolerance to LED placement accuracy
- Precision manufactured in optical grade Polycarbonate for thermal stability and system durability
- Part of the Polymer Optics Limited LED Optics™ range

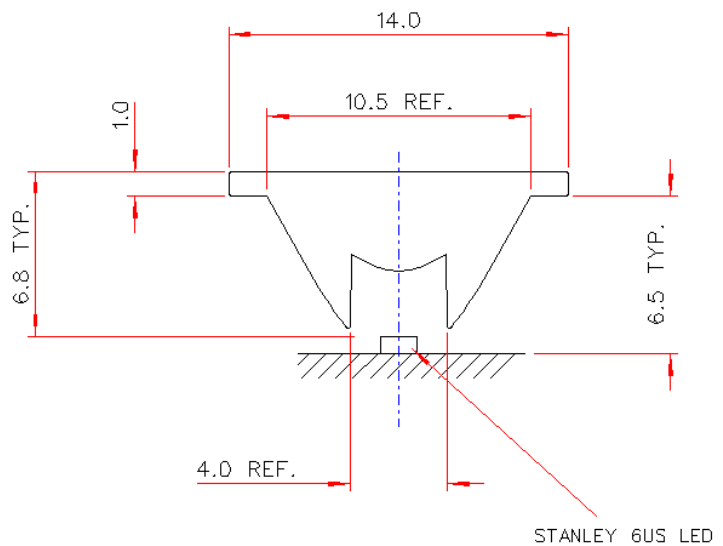
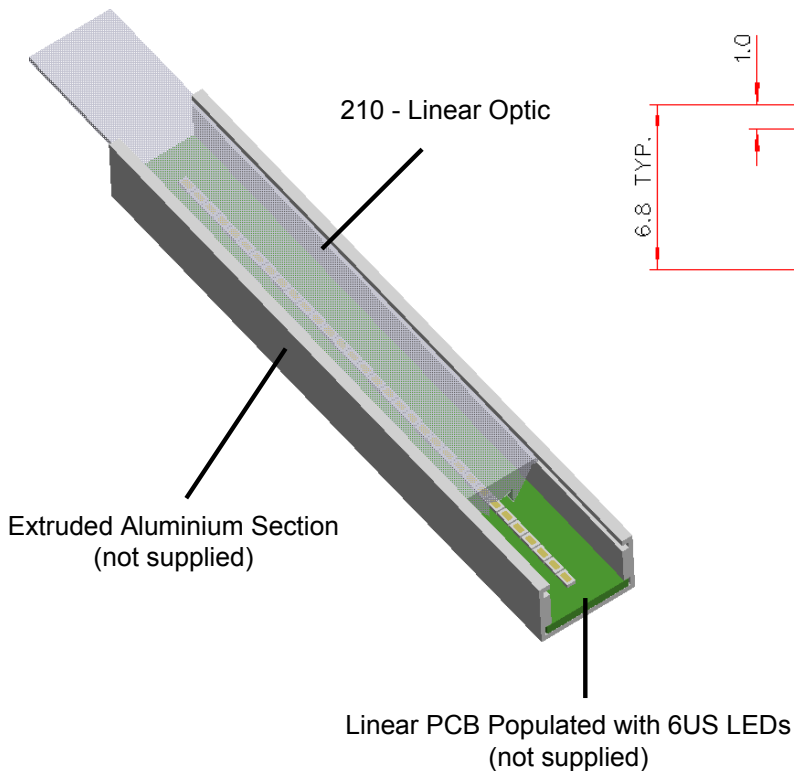

Typical dimensional tolerances to +/-0.2mm





Our Focus is in Plastics

Polymer Optics Ltd.

6 Kiln Ride, Wokingham,
Berks., RG40 3JL, England
Tel/Fax: +44 (0) 1189 893341
www.polymer-optics.co.uk

14mm Linear 15° LED Collimator Optic for Stanley 6US LEDs - Part No. 210

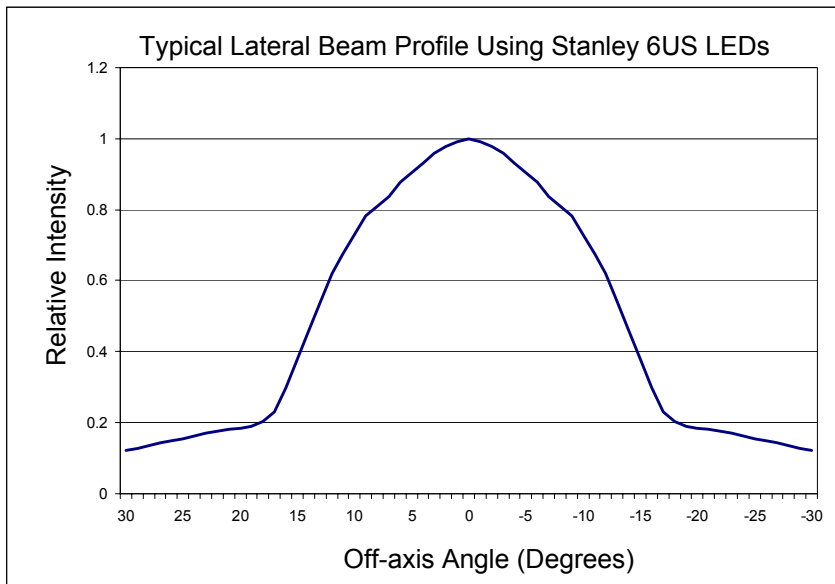

Beam profile in the longitudinal axis is near Lambertian



Performance values given are typical values and will vary dependant on LED spacing, binning, colour and drive profile



Our Focus is in Plastics

Polymer Optics Ltd.

6 Kiln Ride, Wokingham,
Berks., RG40 3JL, England
Tel/Fax: +44 (0) 1189 893341
www.polymer-optics.co.uk

14mm Linear 15° LED Collimator Optic for Stanley 6US LEDs - Part No. 210

- Supplied in standard lengths of 1200mm
- Supplied with a front surface low-tack tape protection layer, to be removed before installation, which improves handling during shipment and product assembly
- Can be easily cut to required length using a hand-saw, table-saw, band-saw (or similar) fitted with a fine tooth blade (appropriate safety precautions must to be taken for the equipment used)
- Alternatively, lay the section flat face down on a stable surface and score across the peaks of the optical form at the required place. Then, bent at the score line towards the flat face and the Linear Optic will snap cleanly at the required point (appropriate safety precautions must to be taken for the equipment used)
- Compact Linear LED Collimator Optic design allows easy assembly to an extruded housing/heat-sink to enable small profile linear luminaires to be created for linear feature illumination and wall-washing applications
- Ideal for applications such as:
 - Wall washing
 - Architectural Feature illumination
 - Fluorescent strip light replacements
 - Under-cupboard lighting
 - Walkway illumination
 - Large backlight coupling
- POL's RoHS statement for this and all other POL products can be found at:- <http://www.polymer-optics.co.uk/POL%20RoHS%20Statement.pdf>





Our Focus is in Plastics

Polymer Optics Ltd.

6 Kiln Ride, Wokingham,
Berks., RG40 3JL, England
Tel/Fax: +44 (0) 1189 893341
www.polymer-optics.co.uk

14mm Linear 15° LED Collimator Optic for Stanley 6US LEDs - Part No. 210

Application Notes:

It should be noted that the thermal coefficient of expansion of polycarbonate ($3.75 \times 10^{-5}/^{\circ}\text{C}$) is higher than the typical thermal coefficient of expansion for an aluminium alloy extruded housing/heatsink ($23.2 \times 10^{-6}/^{\circ}\text{C}$). Therefore, should be taken into consideration in any extended, linear fitting design.

As a guide, a 1200mm long section of the polycarbonate extrusion will expand by $0.045\text{mm}/^{\circ}\text{C}$ raise in temperature, where an aluminium extruded housing of the same length will expand by $0.0278\text{mm}/^{\circ}\text{C}$. Therefore the difference in linear expansion will be $0.0172\text{mm}/^{\circ}\text{C}$.

So, if the 1200mm fitting experiences a temperature rise of 40°C , the polycarbonate Linear Optic will expand by around 0.7mm more than its aluminium housing. It is therefore recommended that some expansion clearance is allowed on the overall length of the Linear Optic in its housing.

Expansion gaps left at the ends of the Linear Optic, or gaps between lengths assembled end to end, can be filled with a silicone based elastomer material or similar flexible sealant/adhesive to allow for the expected expansion movement.

Product Packaging Quantities:



Part No. 210-10Pkt

**10off 1200mm standard lengths of Part No. 210 -
14mm Linear 15° LED Collimator Optic**

Heat sealed in heavy gauge polyethylene flat tube bag

Approximate total weight 675grms



Part No. 210-100Pkt

**100off 1200mm standard lengths of Part No. 210 -
14mm Linear 15° LED Collimator Optic**

**Layer packed in heavy gauge cardboard box with
approximate overall size of 1300mm x 175mm x 105mm**

Approximate total weight 6.6kg