



*Our Focus is in Plastics*

**Polymer Optics Ltd.**

6 Kiln Ride, Wokingham,  
Berks., RG40 3JL, England  
Tel/Fax: +44 (0) 1189 893341  
www.polymer-optics.co.uk

**6 Degree LED Collimator Lens - Part No. 120**



- Designed to operate with Cree Xlamp 7090 High Power LEDs
- High light collection efficiency of >85%
- Precision moulded in optical grade Polycarbonate for thermal stability and system durability
- Part of the Polymer Optics “Modular LED Optics”<sup>®</sup> range

**Polymer Optics “Modular LED Optics”<sup>®</sup> design, based on a hexagonal format, allows maximum packing density and assembly flexibility**

**Supplied with Holder (Part No. 147) to mount optics directly on to PCB’s. Holder locates on LED package to ensure correct alignment**

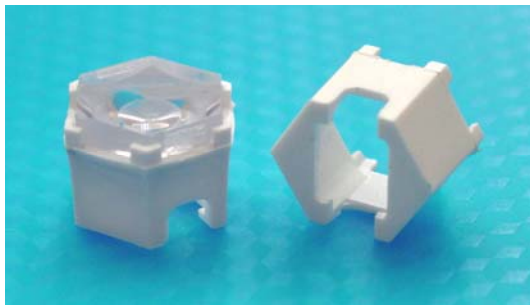

Typical dimensional tolerances to +/-0.2mm

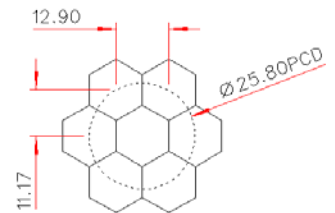
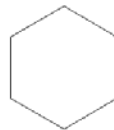

NESTED COMPONENTS ON 25.8MM PCD

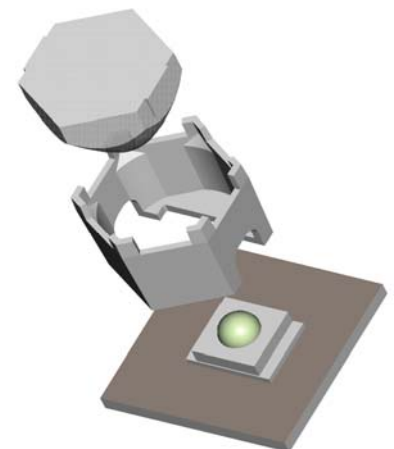
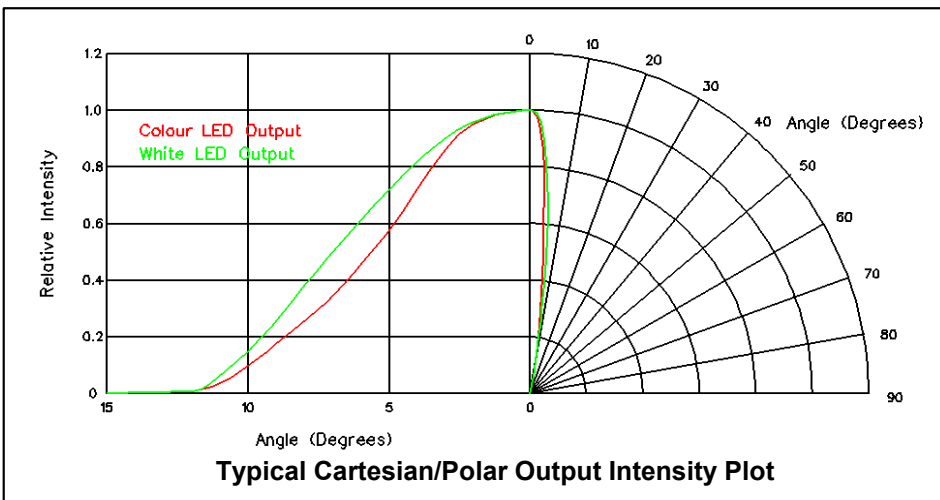
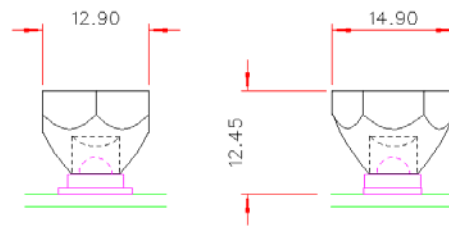

Due to continuous product improvement, POL reserve the right to change specifications without notice.



*Our Focus is in Plastics*

**Polymer Optics Ltd.**

6 Kiln Ride, Wokingham,  
Berks., RG40 3JL, England  
Tel/Fax: +44 (0) 1189 893341  
www.polymer-optics.co.uk

**25 Degree LED Collimator Lens - Part No. 124**



- Designed to operate with Cree Xlamp 7090 High Power LEDs
- High light collection efficiency of >85%
- Precision moulded in optical grade Polycarbonate for thermal stability and system durability
- Part of the Polymer Optics “Modular LED Optics”® range

**Polymer Optics “Modular LED Optics”® design, based on a hexagonal format, allows maximum packing density and assembly flexibility**

**Supplied with Holder (Part No. 147) to mount optics directly on to PCB's. Holder locates on LED package to ensure correct alignment**

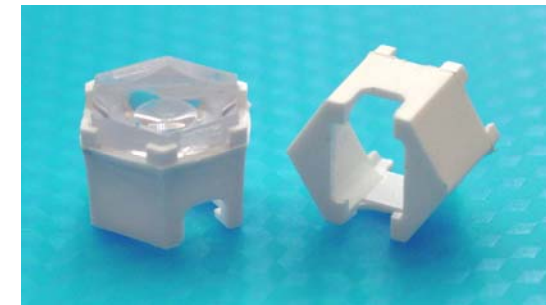

Typical dimensional tolerances to +/-0.2mm

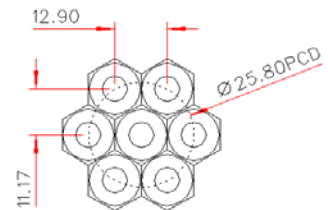
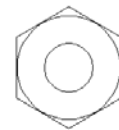

NESTED COMPONENTS ON 25,8MM PCD

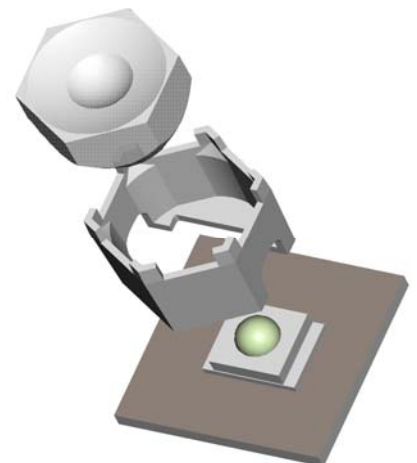
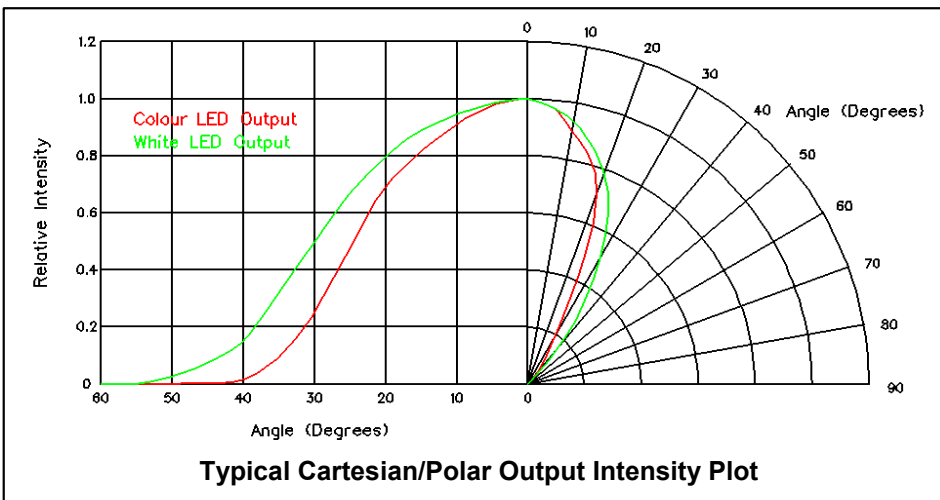
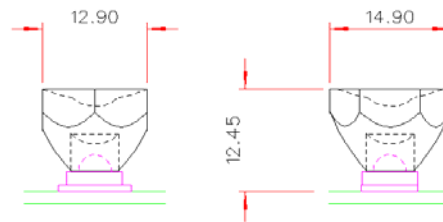

Due to continuous product improvement, POL reserve the right to change specifications without notice.



*Our Focus is in Plastics*

**Polymer Optics Ltd.**

6 Kiln Ride, Wokingham,  
Berks., RG40 3JL, England  
Tel/Fax: +44 (0) 1189 893341  
www.polymer-optics.co.uk

**6x25 Degree LED Line Lens - Part No. 126**

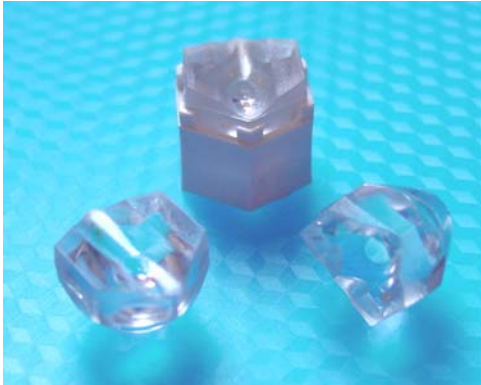

- Designed to operate with Cree Xlamp 7090 High Power LEDs
- High light collection efficiency of >85%
- Precision moulded in optical grade Polycarbonate for thermal stability and system durability
- Part of the Polymer Optics “Modular LED Optics”® range

Typical dimensional tolerances to +/-0.2mm

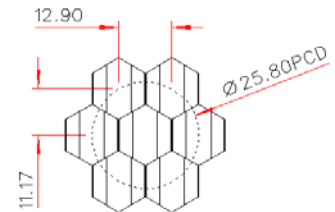
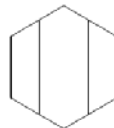

NESTED COMPONENTS ON 25,8MM PCD

Polymer Optics “Modular LED Optics”® design, based on a hexagonal format, allows maximum packing density and assembly flexibility

Supplied with Holder (Part No. 147) to mount optics directly on to PCB's. Holder locates on LE package to ensure correct alignment

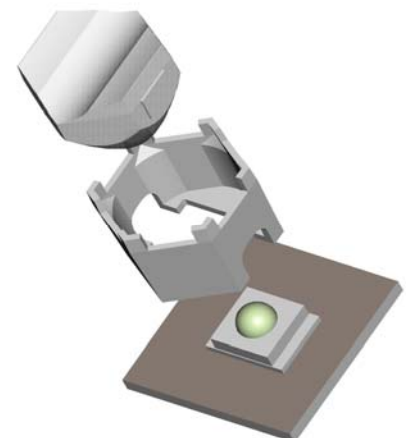
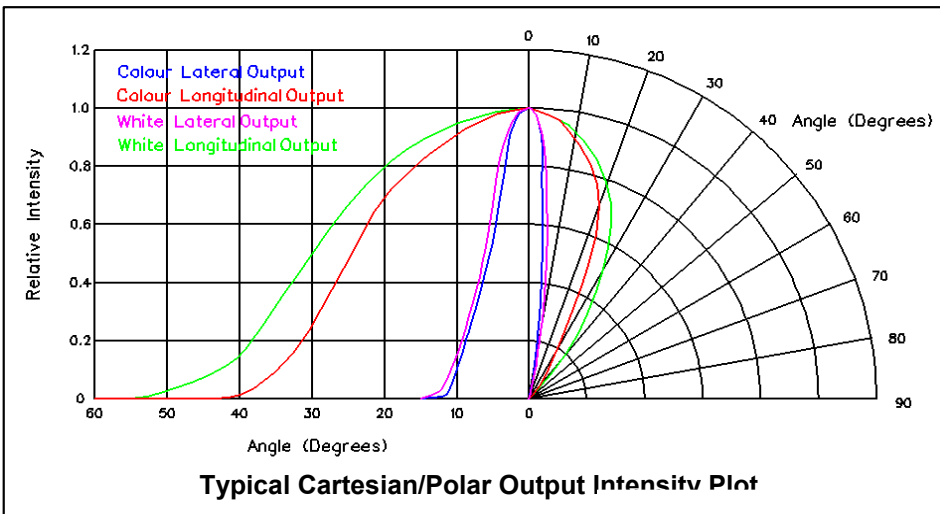
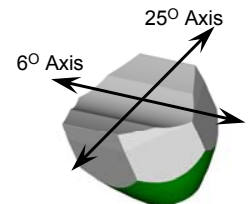
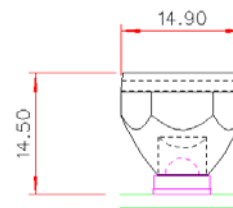
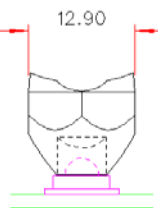

Due to continuous product improvement, POL reserve the right to change specifications without notice.



**Polymer  
Optics  
Limited**

*Our Focus is in Plastics*

**Polymer Optics Ltd.**

6 Kiln Ride, Wokingham,  
Berks., RG40 3JL, England  
Tel/Fax: +44 (0) 1189 893341  
www.polymer-optics.co.uk

**Cree LED Lens Holder - Part No. 147**

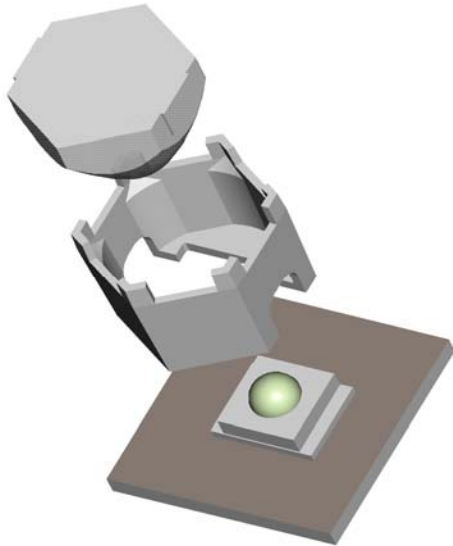

- Designed for use with Polymer Optics “Modular LED Optics”<sup>®</sup> and custom Polymer Optics designs
- Designed to operate with Cree Xlamp 7090 High Power LEDs
- Simply mounts onto PCB and self-aligns to LED
- Precision moulded in optical grade Polycarbonate for thermal stability and system durability
- Part of the Polymer Optics “Modular LED Optics”<sup>®</sup> range

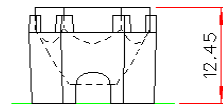

OPTIC AND HOLDER ASSY.

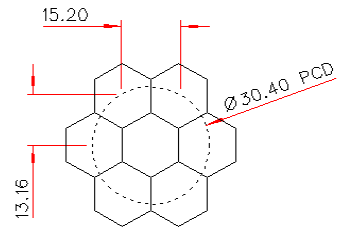

NESTED COMPONENTS ON 30.4MM PCD

Typical dimensional tolerances to +/-0.2mm

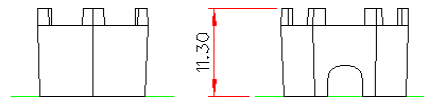
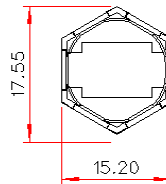

**Polymer Optics “Modular LED Optics”<sup>®</sup> design, based on a hexagonal format, allows maximum packing density and assembly flexibility**

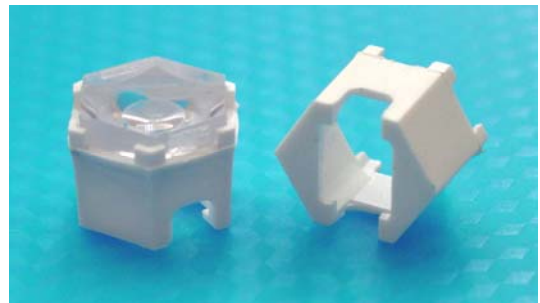
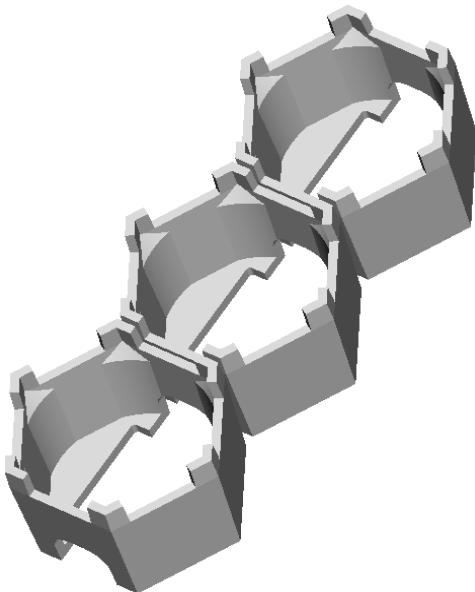



*Our Focus is in Plastics*

**Polymer Optics Ltd.**

6 Kiln Ride, Wokingham,  
Berks., RG40 3JL, England  
Tel/Fax: +44 (0) 1189 893341  
www.polymer-optics.co.uk

**6 Degree LED Collimator 7 Cell Cluster Optic - Part No. 134**

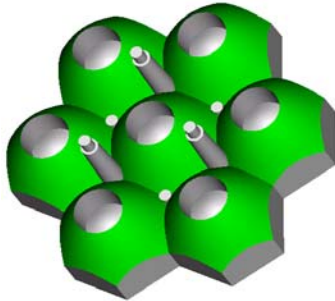

- Designed to operate with Cree Xlamp 7090 High Power LEDs
- High light collection efficiency of >85%
- Precision moulded in optical grade Polycarbonate for thermal stability and system durability
- Part of the Polymer Optics “Modular LED Optics”® range

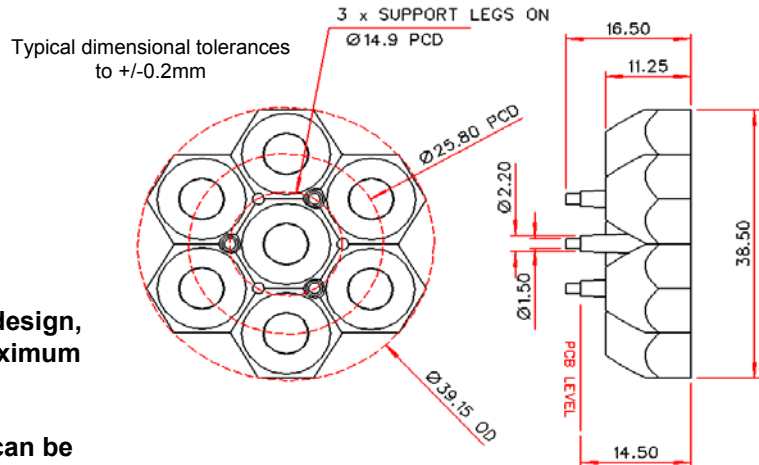
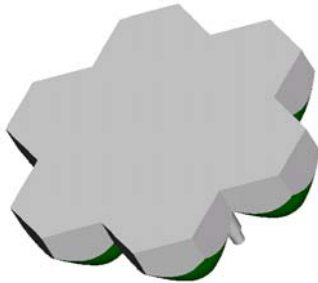

Polymer Optics “Modular LED Optics”® design, based on a hexagonal format, allows maximum packing density and assembly flexibility

Polymer Optics “Cluster Optic”® arrays can be assembled together in a number of ways to meet the needs of a range of illumination applications

The 134 and 135 type “Cluster Optics”® can be mixed in the assembly to optimise the systems illumination distribution, and combined with other Polymer Optics custom cluster designs.

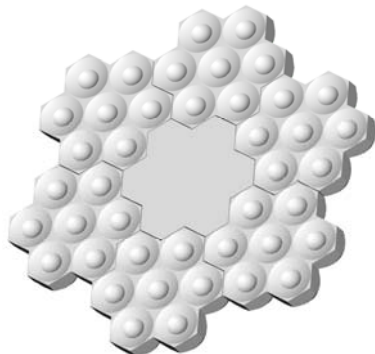

Output beam is rendered homogeneous within only 100mm from front of optic

This gives excellent colour mixing with RGB LED mixes



Due to continuous product improvement, POL reserve the right to change specifications without notice.



**Polymer  
Optics  
Limited**

*Our Focus is in Plastics*

**Polymer Optics Ltd.**

6 Kiln Ride, Wokingham,  
Berks., RG40 3JL, England  
Tel/Fax: +44 (0) 1189 893341  
www.polymer-optics.co.uk

**25 Degree LED Collimator 7 Cell Cluster Optic - Part No. 135**

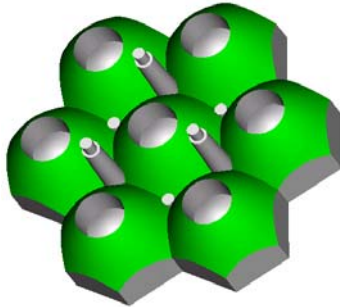

- Designed to operate with Cree Xlamp 7090 High Power LEDs
- High light collection efficiency of >85%
- Precision moulded in optical grade Polycarbonate for thermal stability and system durability
- Part of the Polymer Optics “Modular LED Optics”® range

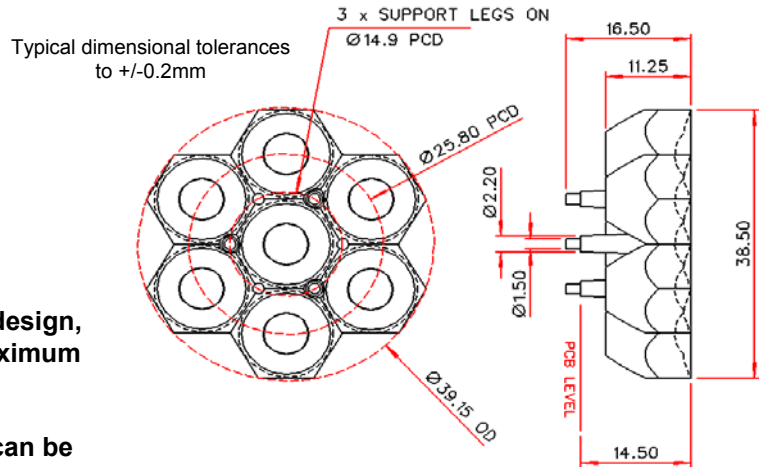
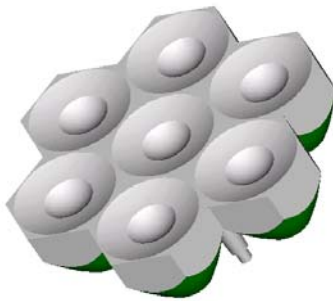

Polymer Optics “Modular LED Optics”® design, based on a hexagonal format, allows maximum packing density and assembly flexibility

Polymer Optics “Cluster Optic”® arrays can be assembled together in a number of ways to meet the needs of a range of illumination applications

The 134 and 135 type “Cluster Optics”® can be mixed in the assembly to optimise the systems illumination distribution, and combined with other Polymer Optics custom cluster designs.

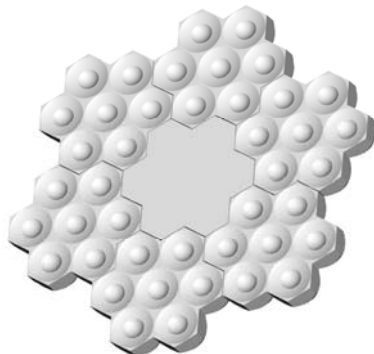

**Output beam is rendered homogeneous within only 100mm from front of optic**

**This gives excellent colour mixing with RGB LED mixes**

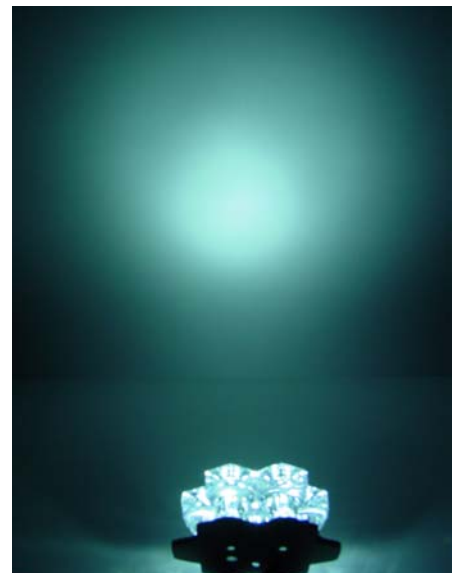

Due to continuous product improvement, POL reserve the right to change specifications without notice.

© Copyright Polymer Optics Limited 2008



*Our Focus is in Plastics*

**Polymer Optics Ltd.**

6 Kiln Ride, Wokingham,  
Berks., RG40 3JL, England  
Tel/Fax: +44 (0) 1189 893341  
www.polymer-optics.co.uk

**7 Cell Cluster Zoom Optic - Part No. 130**

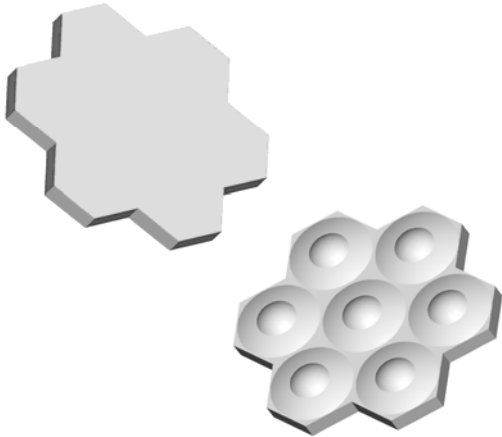

- Designed to operate with Cree Xlamp 7090 High Power LEDs
- Variable zoom capability from 6 degrees to 45 degree half angles (Patent applied for design and concept)
- Used with Part No. 135. Zoom optic simply requires to be moved forward and rotated on a coarse thread action.
- Precision moulded in optical grade Polycarbonate for thermal stability and system durability
- Part of the Polymer Optics “Modular LED Optics”® range

ROTATE ZOOM OPTIC BY 30°

Typical dimensional tolerances  
to +/-0.2mm

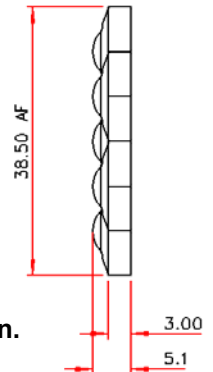
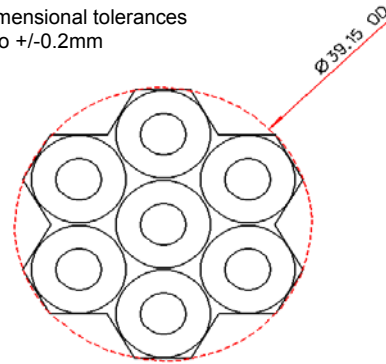
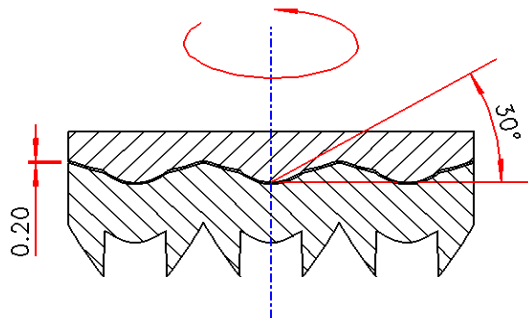

Initial 6° beam is achieved with Zoom Optic nested on Part No. 135 with 0- 0.2mm separation. Rotate Zoom Optic about its axis on a thread angle of 30° by only 30° to achieve 45° beam. Thread pitch equates to 45mm per turn, or 0.6 turns per inch.



**6° Position**



**Mid Position**



**Wide Angle Position**

**Beam homogeneity is achieved beyond 1m from optic and is suitable for RGB colour mixing PCB layouts**

Due to continuous product improvement, POL reserve the right to change specifications without notice.



*Our Focus is in Plastics*

**Polymer Optics Ltd.**

6 Kiln Ride, Wokingham,  
Berks., RG40 3JL, England  
Tel/Fax: +44 (0) 1189 893341  
www.polymer-optics.co.uk

## Single Cell LED Concentrator Lens - Part No. 141

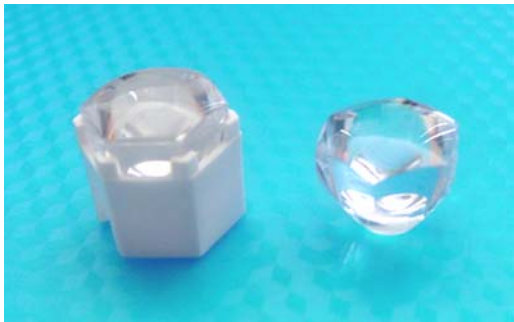

- Designed to operate with Cree Xlamp 7090 High Power LEDs
- High light collection efficiency of >85%
- Precision moulded in optical grade Polycarbonate for thermal stability and system durability
- Part of the Polymer Optics “Modular LED Optics”<sup>®</sup> range

Polymer Optics “Modular LED Optics”<sup>®</sup> design, based on a hexagonal format, allows maximum packing density and assembly flexibility

Supplied with Holder (Part No. 147) to mount optics directly on to PCB's. Holder locates on LED package to ensure correct alignment

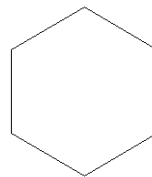

Typical dimensional tolerances to +/-0.2mm

Beam waist Ø6mm

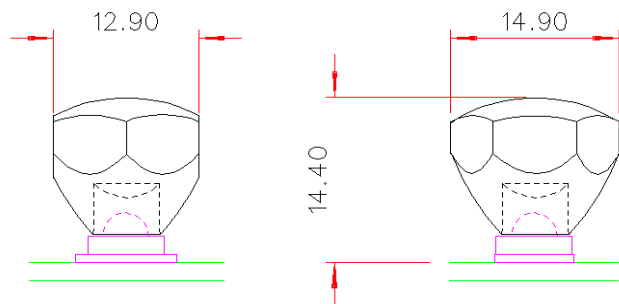
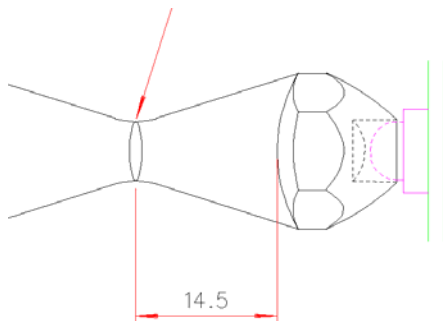

### Typical Applications:

- Beam insertion into optical fibre bundles
- Beam insertion into edge of lightguides
- High intensity illumination of small objects for inspection and microscopy



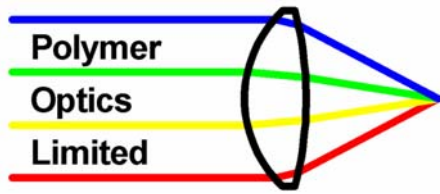

*Our Focus is in Plastics*

**Polymer Optics Ltd.**

6 Kiln Ride, Wokingham,  
Berks., RG40 3JL, England  
Tel/Fax: +44 (0) 1189 893341  
www.polymer-optics.co.uk

### 7 Cell Cluster Concentrator Optic - Part No. 145

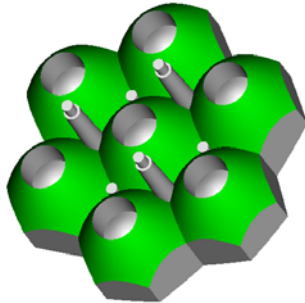

- Designed to operate with Cree Xlamp 7090 High Power LEDs
- High light collection efficiency of >85%
- Precision moulded in optical grade Polycarbonate for thermal stability and system durability
- Part of the Polymer Optics “Modular LED Optics”® range

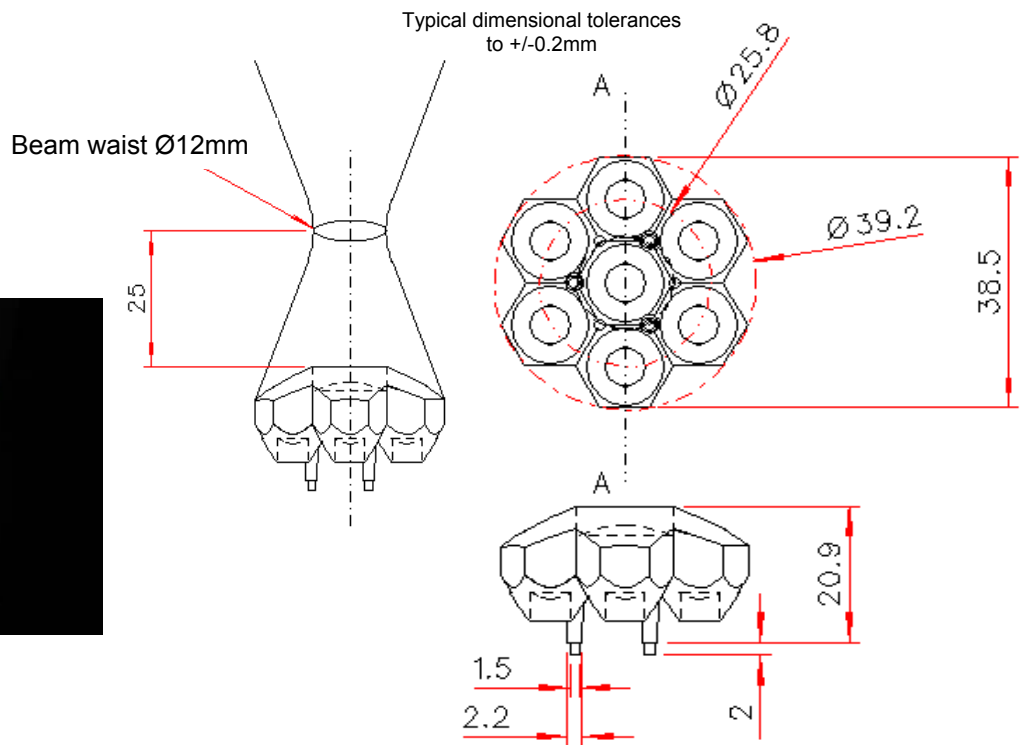
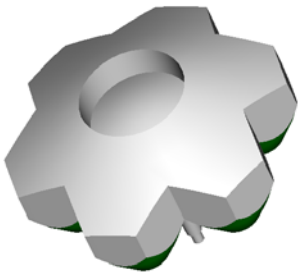

#### Typical Applications:

- Beam insertion into optical fibre bundles
- Beam insertion into edge of lightguides
- High intensity illumination of small objects for inspection and microscopy

Polymer Optics “Modular LED Optics”® design, based on a hexagonal format, allows maximum packing density and assembly flexibility

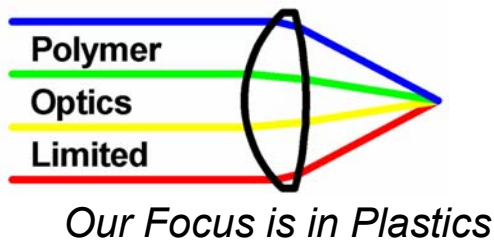

**Polymer Optics Ltd.**

6 Kiln Ride, Wokingham,  
Berks., RG40 3JL, England  
Tel/Fax: +44 (0) 1189 893341  
www.polymer-optics.co.uk

**6 Degree Diffuse LED Collimator Lens - Part No. 185**

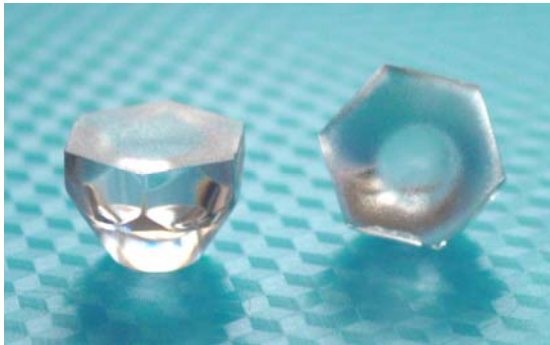

- Designed to operate with Cree Xlamp 7090 High Power LEDs
- High light collection efficiency of >85%
- Diffuse output surface for improved beam uniformity
- Precision moulded in optical grade Polycarbonate for thermal stability and system durability
- Part of the Polymer Optics “Modular LED Optics”® range

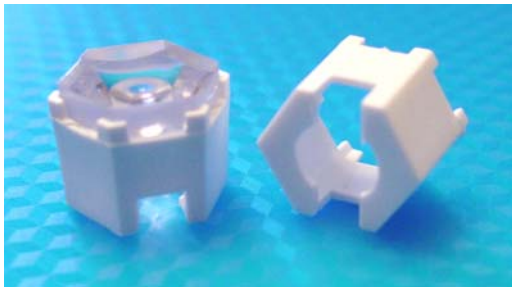

Typical dimensional tolerances to +/-0.2mm

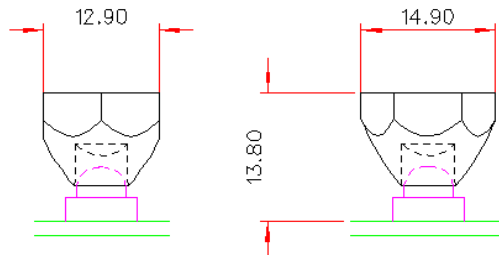
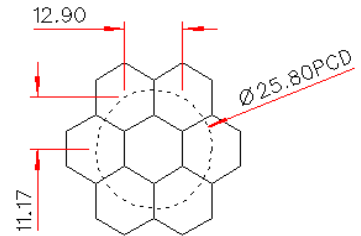
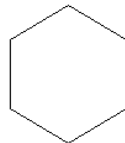

**Polymer Optics “Modular LED Optics”® design, based on a hexagonal format, allows maximum packing density and assembly flexibility**

**Supplied with Holder (Part No. 147) to mount optics directly on to PCB's. Holder locates on LED package to ensure correct alignment**



*Our Focus is in Plastics*

**Polymer Optics Ltd.**

6 Kiln Ride, Wokingham,  
Berks., RG40 3JL, England  
Tel/Fax: +44 (0) 1189 893341  
www.polymer-optics.co.uk

## 15 Degree LED Collimator Lens - Part No. 201



- Specifically designed for Cree Xlamp 7090 High Power LEDs
- High light collection efficiency of >85%
- Precision moulded in optical grade Polycarbonate for thermal stability and system durability
- Part of the Polymer Optics “Modular LED Optics”<sup>®</sup> range

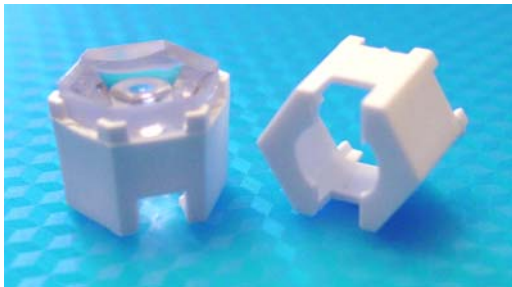

Typical dimensional tolerances  
to +/-0.2mm

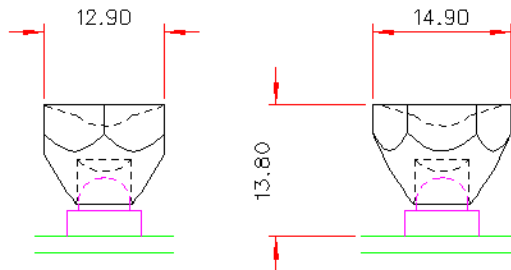
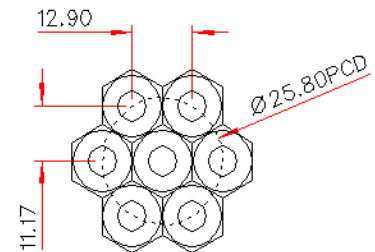
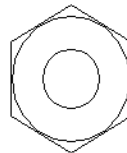

**Polymer Optics “Modular LED Optics”<sup>®</sup> design, based on a hexagonal format, allows maximum packing density and assembly flexibility**

**Supplied with Holder (Part No. 147) to mount optics directly on to PCB's. Holder locates on LED package to ensure correct alignment**



*Our Focus is in Plastics*

**Polymer Optics Ltd.**

6 Kiln Ride, Wokingham,  
Berks., RG40 3JL, England  
Tel/Fax: +44 (0) 1189 893341  
www.polymer-optics.co.uk

**Diffuse 6x25 Degree LED Collimator Lens - Part No. 216**

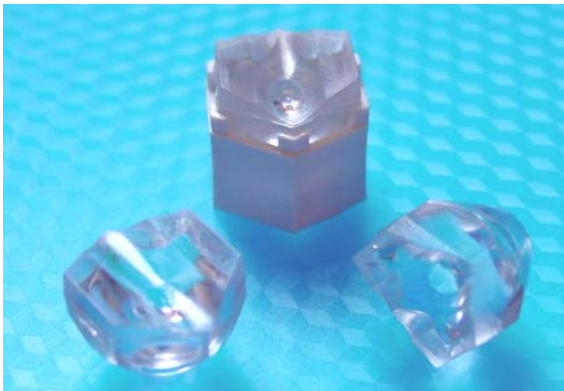

- Designed to operate with Cree Xlamp 7090 High Power LEDs
- High light collection efficiency of >85%
- Diffuse output surface for improved beam uniformity
- Precision moulded in optical grade Polycarbonate for thermal stability and system durability
- Part of the Polymer Optics “Modular LED Optics”® range

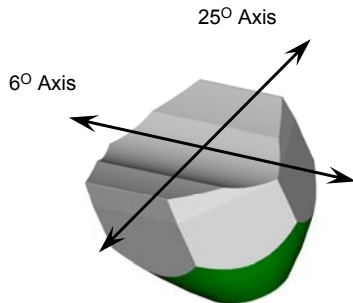

Typical dimensional tolerances to +/-0.2mm

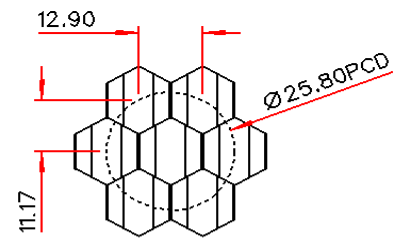
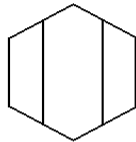

NESTED COMPONENTS ON 25,8MM PCD

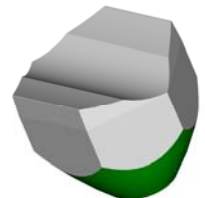
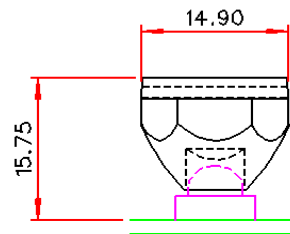
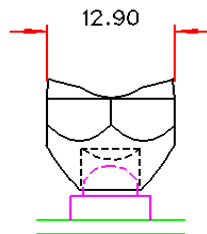

**Polymer Optics “Modular LED Optics”® design, based on a hexagonal format, allows maximum packing density and assembly flexibility**

**Supplied with Holder (Part No. 147) to mount optics directly on to PCB's. Holder locates on LED package to ensure correct alignment**



*Our Focus is in Plastics*

**Polymer Optics Ltd.**

6 Kiln Ride, Wokingham,  
Berks., RG40 3JL, England  
Tel/Fax: +44 (0) 1189 893341  
www.polymer-optics.co.uk

**Diffuse 25 Degree LED Collimator Lens - Part No. 217**



- Designed to operate with Cree Xlamp 7090 High Power LEDs
- High light collection efficiency of >85%
- Diffuse output surface for improved beam uniformity
- Precision moulded in optical grade Polycarbonate for thermal stability and system durability
- Part of the Polymer Optics “Modular LED Optics”<sup>®</sup> range

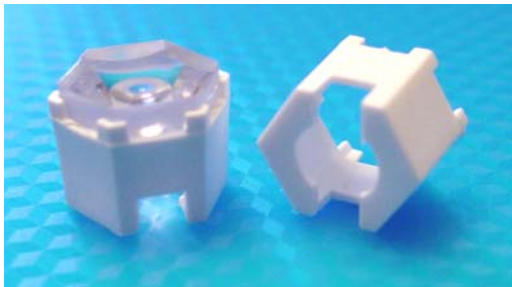

Typical dimensional tolerances to +/-0.2mm

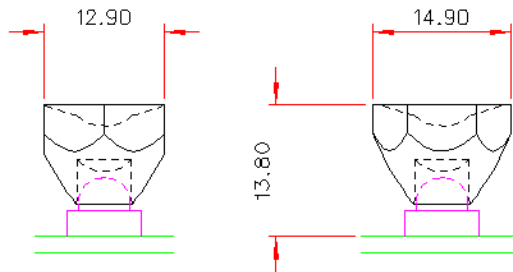
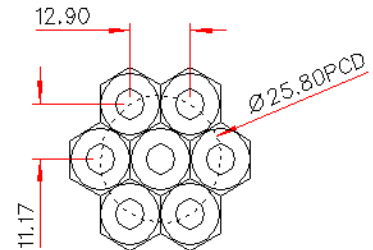
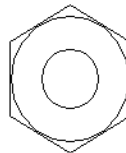

**Polymer Optics “Modular LED Optics”<sup>®</sup> design, based on a hexagonal format, allows maximum packing density and assembly flexibility**

**Supplied with Holder (Part No. 147) to mount optics directly on to PCB's. Holder locates on LED package to ensure correct alignment**



*Our Focus is in Plastics*

**Polymer Optics Ltd.**

6 Kiln Ride, Wokingham,  
Berks., RG40 3JL, England  
Tel/Fax: +44 (0) 1189 893341  
[www.polymer-optics.co.uk](http://www.polymer-optics.co.uk)

**Cree High Power LED Optic Product Summary and Price List**

Product Image	Description	Usage	100-1K Batches	1K-5K Batches	5K-10K Batches	10K+ Batches
 120/147	6° Collimator + Std Holder	Cree Xlamp 7090 High Power LED	£1.25	£0.98	£0.77	£0.72
 124/147	25° Collimator + Std Holder	Cree Xlamp 7090 High Power LED	£1.25	£0.98	£0.77	£0.72
 126/147	6°x25° Line + Std Holder	Cree Xlamp 7090 High Power LED	£1.25	£0.98	£0.77	£0.72
 130	7 Cell Cluster Zoom Optic	Must be used with Part No. 135	£3.50	£3.25	£2.75	£2.50
 134	7 Cell Cluster 6° Collimator	Cree Xlamp 7090 High Power LED	£4.75	£4.50	£4.00	£3.75
 135	7 Cell Cluster 25° Collimator	Cree Xlamp 7090 High Power LED	£4.75	£4.50	£4.00	£3.75
 141/147	Single Cell Concentrator	Cree Xlamp 7090 High Power LED	£1.25	£0.98	£0.77	£0.72

A minimum order value £50+shipping - All prices “ex-works” Please contact POL for higher volumes and custom variants







*Our Focus is in Plastics*

**Polymer Optics Ltd.**

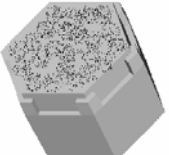
6 Kiln Ride, Wokingham,  
Berks., RG40 3JL, England  
Tel/Fax: +44 (0) 1189 893341  
www.polymer-optics.co.uk

**Cree High Power LED Optic Product Summary and Price List**

Product Image	Description	Usage	100-1K Batches	1K-5K Batches	5K-10K Batches	10K+ Batches
 145	7 Cell Cluster Concentrator	Cree <del>Xlamp</del> 7090 High Power LED	£4.75	£4.50	£4.00	£3.75
 185/147	Diffuse 6° Collimator + Std Holder	Cree <del>Xlamp</del> 7090 High Power LED	£1.25	£0.98	£0.77	£0.72
 201/147	15° Collimator + Std Holder	Cree <del>Xlamp</del> 7090 High Power LED	£1.25	£0.98	£0.77	£0.72
 216/147	Diffuse 6°x25° Line + Std Holder	Cree <del>Xlamp</del> 7090 High Power LED	£1.25	£0.98	£0.77	£0.72
 217/147	Diffuse 25° Collimator + Std Holder	Cree <del>Xlamp</del> 7090 High Power LED	£1.25	£0.98	£0.77	£0.72

A minimum order value £50+shipping - All prices “ex-works” Please contact POL for higher volumes and custom variants