

30mm Colour Mixer Reflector - Part No. 234



- Designed for Edison “EdiPower” RGB and RGBA LEDs or similar LED packages
- Colour mixing chamber design provides uniform beam colour, which with the output reflector optic, provides a narrow colour mixed beam
- Narrow beam angle of 5 degrees half angle, 10 degrees FWHM (full width half maximum intensity)
- Optical efficiency of >60%
- Also available for other Edison “EdiPower” and “Edixeon” LED types

Precision moulded using POL’s patent applied for metallised optical insert moulding technique with a polycarbonate frame construction for superior mechanical and thermal stability

Polymer Optics “Modular LED Optics”[®] design, based on a hexagonal format, allows maximum packing density and assembly flexibility. Arrays of Colour Mixer Reflector optics can be easily constructed to produce high power luminaire designs

The 234 Reflector Optic base is designed to mount over the EdiPower LED package to align to the LED source and provides a colour mixed beam for collimation by the reflector optic.

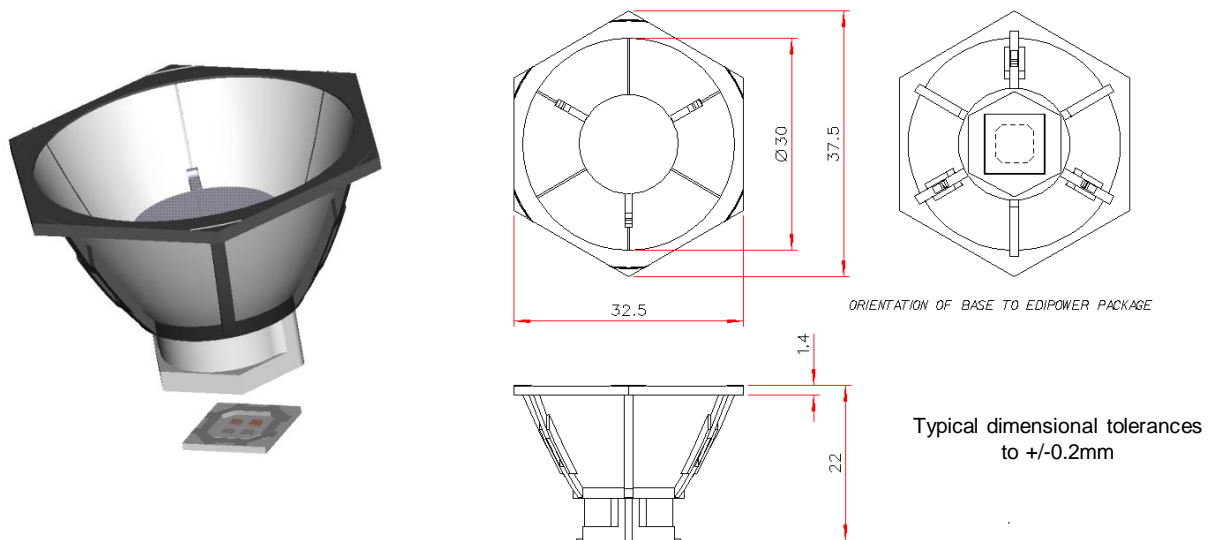

In order to determine if the particular beam properties and performance of this optic are suitable for your application with your chosen LED type, POL suggests that you obtain samples from POL or their distributors for your own product testing, as properties may vary with different LED types.

Due to continuous product improvement, POL reserve the right to change specifications without notice.

© Copyright Polymer Optics Limited 2016

30mm Colour Mixer Reflector - Part No. 234

The perfect colour mixing achieved with the POL 234 optic allows an infinite range of illumination colours to be produced with a constant and stable beam geometry.

An additional advantage is that the appearance of the emitted light from the POL 234 optic is a uniform mixed colour too, removing the usual visible spots of RGB seen in other colour mixing products.

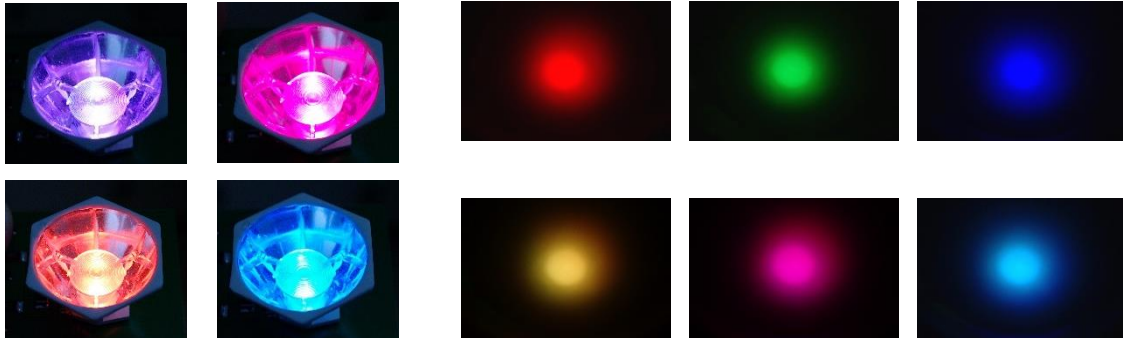

The POL 234 optic's narrow, high intensity beam is ideal for demanding applications, such as:



- ✓ Architectural spot lights
- ✓ Theatrical lights and follow-spots
- ✓ Forensic torches
- ✓ Medical lighting applications

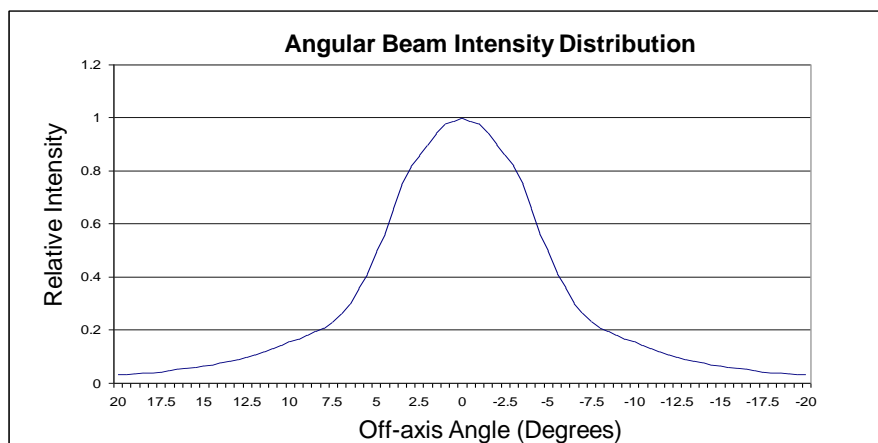

In order to determine if the particular beam properties and performance of this optic are suitable for your application with your chosen LED type, POL suggests that you obtain samples from POL or their distributors for your own product testing, as properties may vary with different LED types.

Due to continuous product improvement, POL reserve the right to change specifications without notice.

© Copyright Polymer Optics Limited 2016

30mm Colour Mixer Reflector - Part No. 234

30mm Reflector Beam Converters in the Polymer Optics range:



265 – Medium Beam Converter



266 – Wide Beam Converter



267 – Elliptical Beam Converter

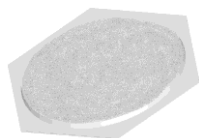

365 – Diffuse Beam Converter

Product Numbering:

The Reflector Converter optics are simply ordered with the required 30mm Reflector optic product, chosen from the POL range, to suit the target LED device.

The required Reflector Converter part number is simply prefixed to the base 30mm Reflector variant. So, for example, if ordering the basic POL 234 - 30mm Reflector with the 267 – Elliptical Beam Converter, the product part number will be 267/234.

Please see the entire range of POL 30mm Reflector Optic products for options, or enquire to POL for further information.

Due to continuous product improvement, POL reserve the right to change specifications without notice.

© Copyright Polymer Optics Limited 2016