

Part No. 440
UL1638 Wall Optic Clear

Designed for wall mounted visual alarm devices meeting UL1638 requirements. This optic is designed to produce the Luminous Intensity distribution required by UL1638 with exceptional efficiency.

A typical installation of the optic in an enclosure is shown below:

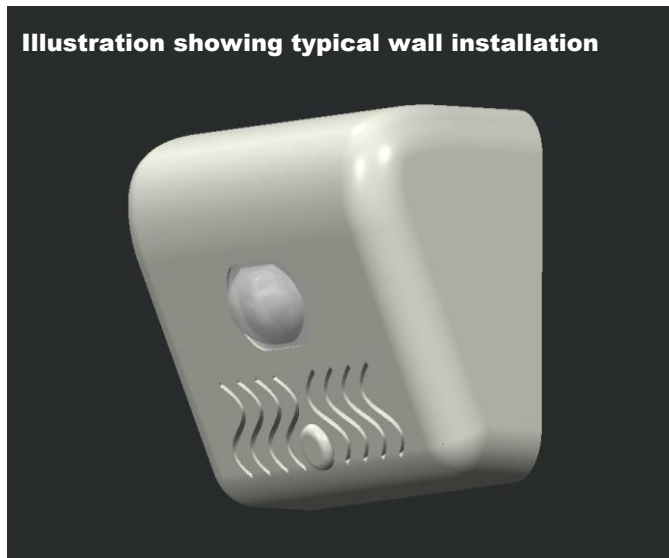

- Designed for Cree XP-E2, XP-G2, XM-L2, XHP35, Luxeon Rebel, and Luxeon TX, (other LEDs may be used).
- Achieves a rating of up to 0.38cd per effective lumen LED output, (dependent on LED used).
- Light transmission efficiency of 85%
- Precision moulded in optical grade Polycarbonate meeting the V-2 flammability rating.

Part No. 440 UL1638 Wall Optic Clear

The graph below shows the measured luminous intensity output of the optic, (in blue) in the horizontal plane when illuminated using a Cree XP-L2 LED emitting 250 effective lumens. The UL1638 limits for a 90 Cd device are shown in red.

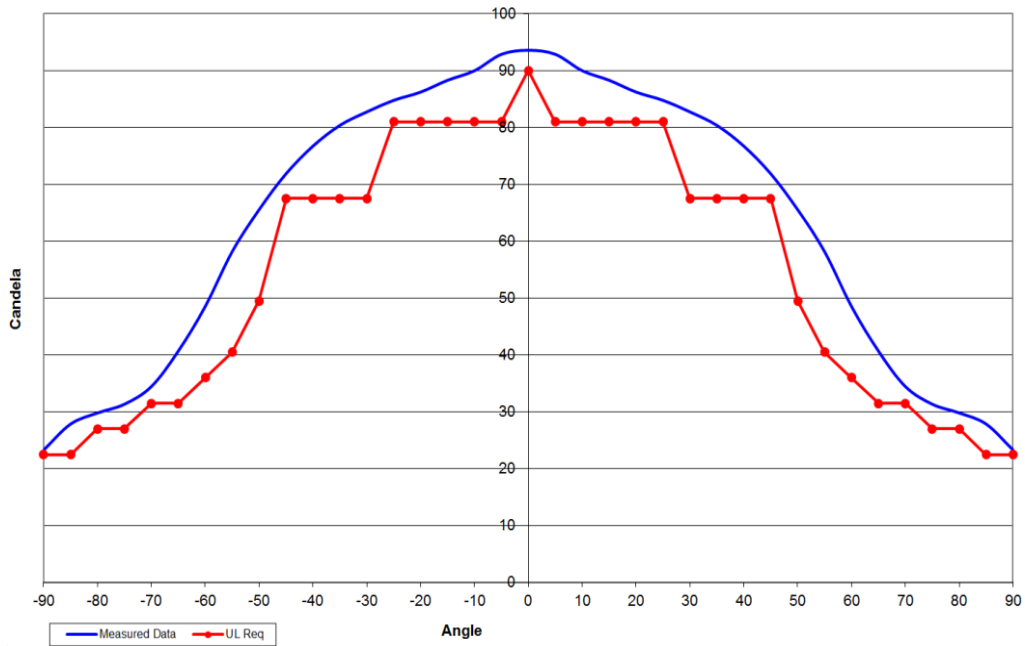

The graph below shows the measured luminous intensity output of the optic, (in blue) in the vertical plane when illuminated using a Cree XP-L2 LED emitting 250 effective lumens. The UL1638 limits for a 90 Cd device are shown in red.

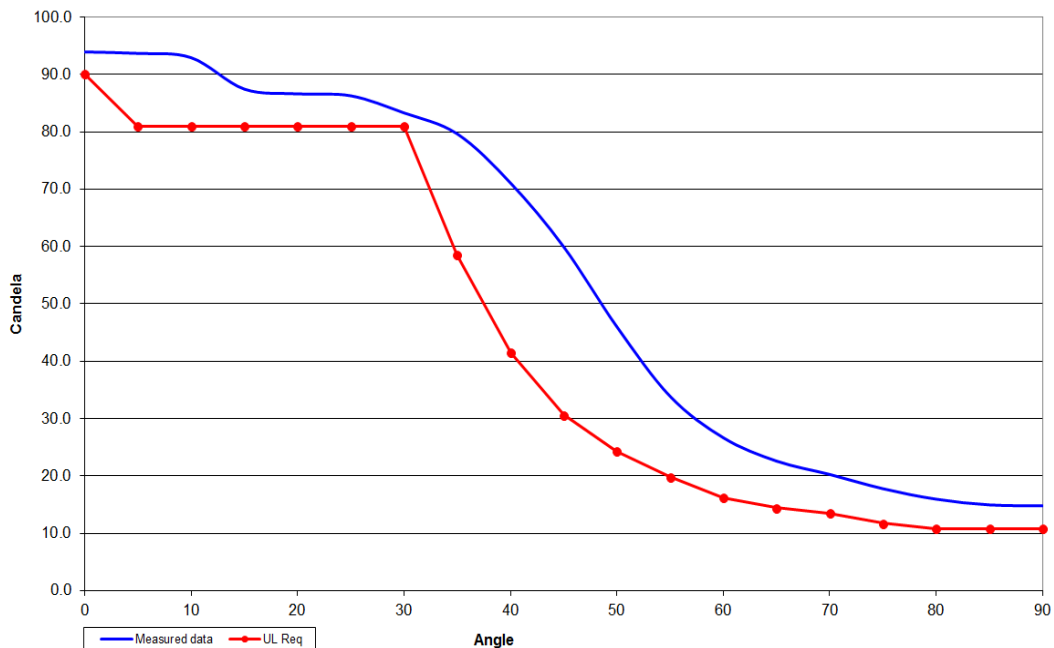

Part No. 440
UL1638 Wall Optic Clear

If viewed using Adobe Acrobat, the picture below can be seen as a 3D interactive model of the part. Click on the picture to activate.

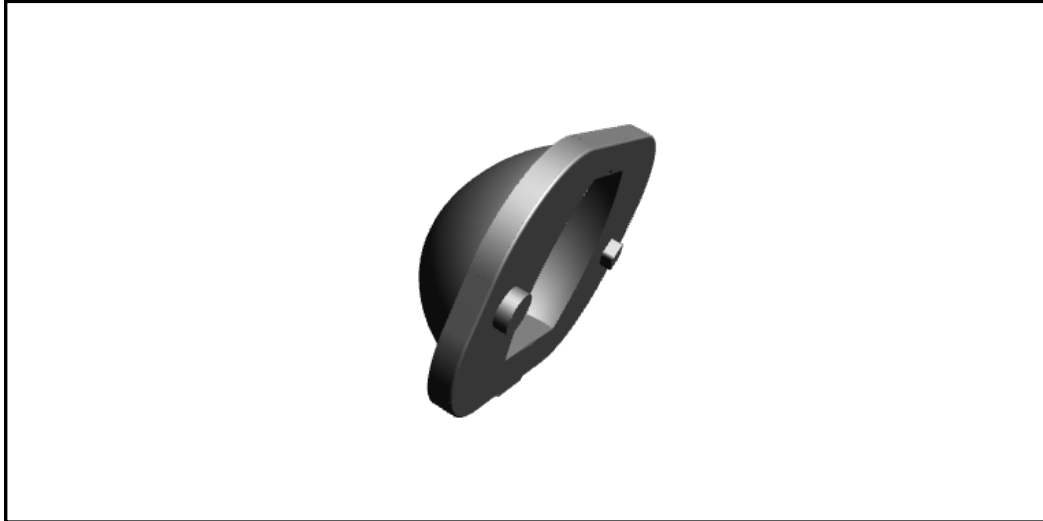

The optic is located on the PCB using a diamond dowel inserted in to a 2.5mm diameter hole and a peg in to a 3mm diameter hole. The distance between the two hole centres required is 20mm. (See dimensional drawing overleaf).

The optic is designed to be mounted at an angle of 25° to the vertical with the gate vestige facing upwards. The maximum size of the lip of a retaining cover placed over the optic is shown below:

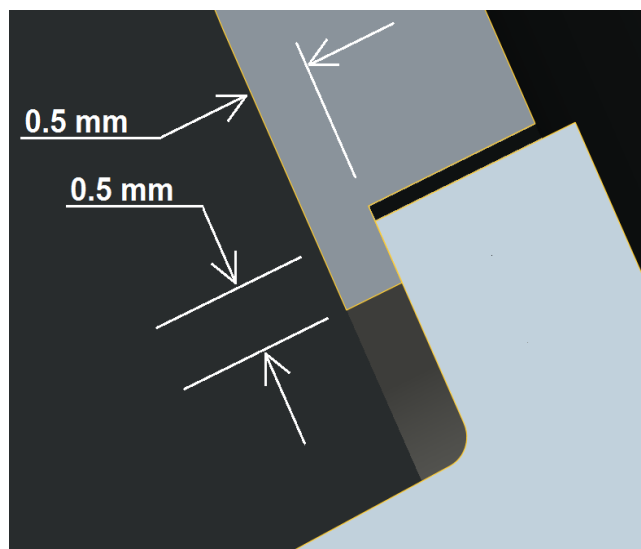
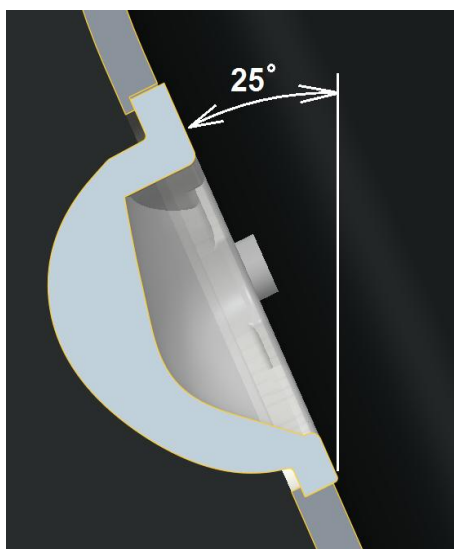



Part No. 440 UL1638 Wall Optic Clear

Typical dimensional tolerances to
+/-0.2mm

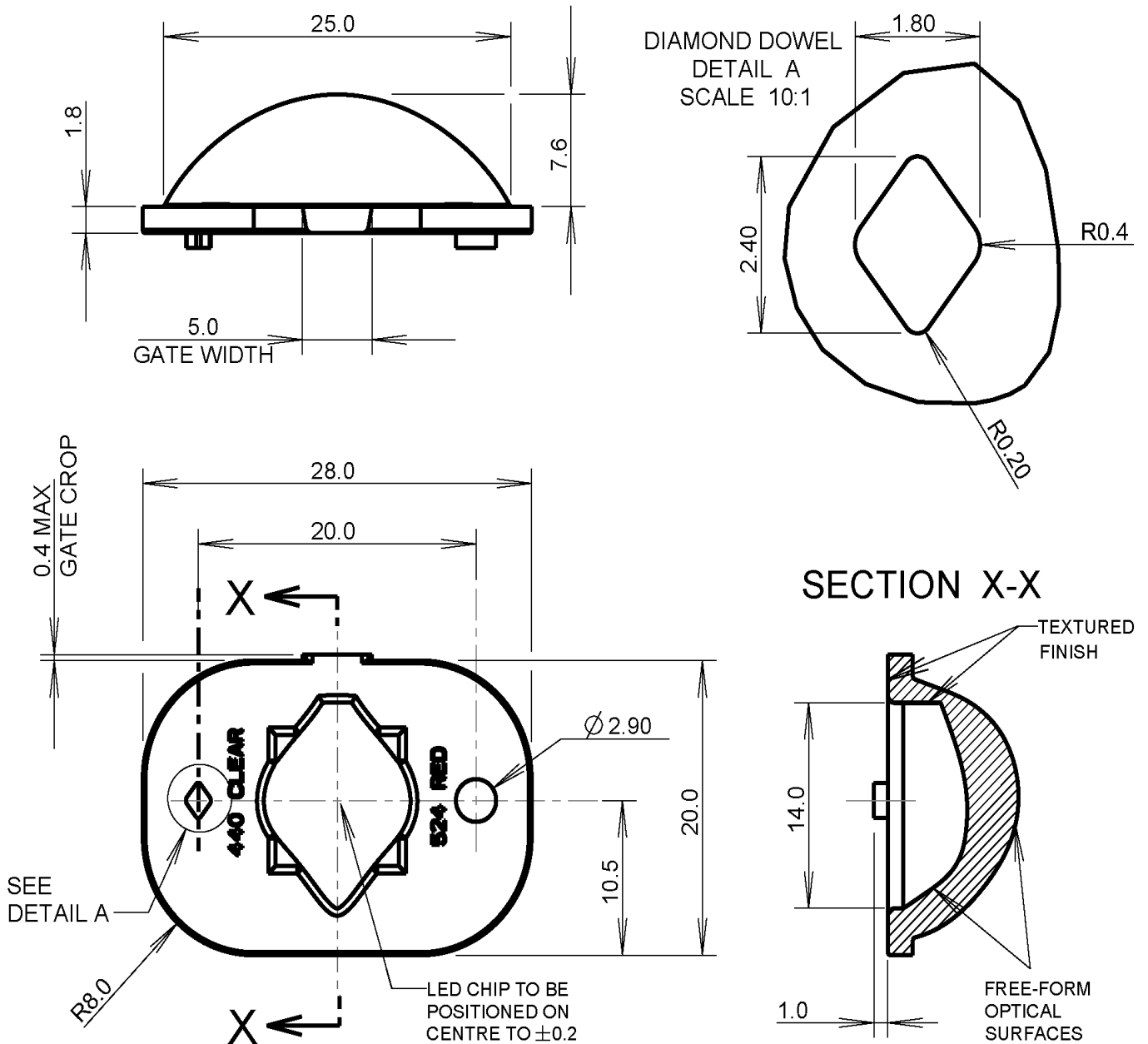

In order to determine if the particular beam properties and performance of this optic are suitable for your application POL suggests that you obtain samples from POL or their distributors for your own product testing.

Due to continuous product improvement, POL reserve the right to change specifications without notice.